

Simulation and Experimental Results of Low Noise SMPS System using Forward Converter

P. Vijaya Kumar¹ S. Rama Reddy²

Abstract–Simulation and Implementation of DC-DC converter side in SMPS system is discussed in this paper. A forward type soft switching DC-DC converter topology with neutral point inductor connected Auxiliary resonant snubber (NPC-ARS) circuit is presented in this paper for the switching mode power supply applications. Its circuit operation and its performance characteristics of the forward type soft switching DC-DC converter are described and the simulation and experimental results are presented.

Keywords- Forward type DC-DC converter, Zero voltage soft switching, Zero current soft switching, neutral point inductor connected Auxiliary resonant snubber (NPC-ARS) circuit.

I. INTRODUCTION

In recent years, the switching mode power supply (SMPS) system have been achieved with high power density and high performances by using power semiconductor devices such as IGBT, MOS-FET and SiC. However, using the switching power semiconductor in the SMPS system, the problem of the switching loss and EMI/RFI noises have been closed up. This course produced the EMC limitation like the International Special Committee on Radio Interference (CISPR) and the harmonics limitation like the International Electro technical Commission (IEC). For keeping up with the limitation, the SMPS system must add its system to the noise filter and the metal and magnetic component shield for the EMI/RFI noises and to the PFC converter circuit and the large input filter for the input harmonic current. On the other hand, the power semiconductor device technology development can achieve the high frequency switching operation in the SMPS system.

The increase of the switching losses has been occurred by this high frequency switching operation. Of course, the inductor and transformer size have been reduced by the high frequency switching, while the size of cooling fan could be huge because of the increase of the switching losses. Our research target is to reduce the EMI/RFI noises and the switching losses in the SMPS system by only one method. The solution method is the soft switching technique. Using LC resonant phenomenon, this technique can minimize the switching power losses of the power semiconductor devices, and reduce their electrical dynamic and peak stresses, voltage and current surge-related EMI/RFI noises under high frequency switching strategy.

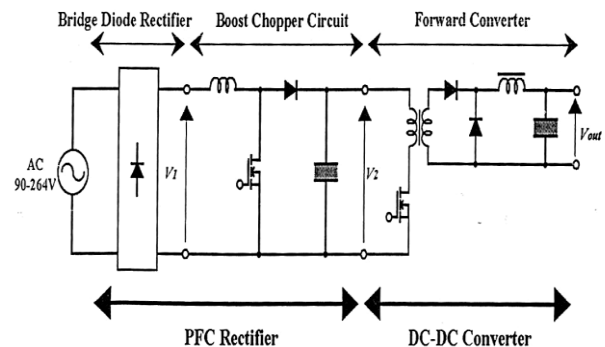

Fig.1.a: SMPS configuration of research target.

Thus, a new conceptual circuit configuration of the advanced forward type soft switching DC - DC converter which has the neutral point inductor connected auxiliary resonant snubber (NPC-ARS) circuit is presented in this paper with its operating principle in steady state. In addition, its fundamental operation and its performance characteristics of the proposed forward type soft switching DC-DC converter treated here are evaluated on the basis of experimental results. A New Controller scheme for Photo voltaics power generation system is presented in [1]. The design and implementation of an adaptive tuning system based on desired phase margin for digitally controlled DC to DC Converters is given in [2]. Integration of frequency response measurement capabilities in digital controllers for DC to DC Converters is given in [3]. A New single stage, single phase, full bridge converter is presented in [4]. The Electronic ballast control IC with digital phase control and lamp current regulation is given in [5]. A New soft-switched PFC Boost rectifier/inverter is presented in [6]. Design of Single-Inductor Multiple-Output DC-DC Buck Converters is presented in [7]. Boost Converter with Improved Performance through RHP Zero Elimination is given by [8]. High-efficiency dc-dc converter with high voltage gain and reduced switch stress is given in [9]. Snubber design for noise reduction is given in [10]. Comparison of active clamp ZVT techniques applied to tapped inductor DC-DC converter is given in [11]. The multiple output AC/DC Converter with an internal DC UPS is given in [12]. The Bi-directional isolated DC-DC Converter for next generation power distribution –comparison of converters using Si and Sic devices is given in [13]. The above literature does not deal with embedded implementation of SMPS System employing forward converter. This work aims to implement SMPS System using low cost embedded Controller.

II. NOVEL FORWARD TYPE SOFT SWITCHING DC-DC CONVERTER

The typical switching mode power supply circuit

The paper first received 8 Sep 2009 and in revised form 21 Oct 2010.
Digital Ref: APEJ-2010-01-0245

¹ Jawaharlal Nehru Technological University Jerusalem College of Engineering Hyderabad, India, E-mail: dvvijayarani@rediffmail.com

²Electrical and Electronics Department, Jerusalem College of Engineering, Chennai India, E-mail: srr_victory@yahoo.com

configuration of our research target is shown in Fig.1.a. We have modified the part of DC-DC converter to achieve the complete soft switching operation in active power semiconductor devices of the forward converter. Fig.1.b shows the schematic configuration of the modified forward type soft switching DC-DC converter with a neutral point inductor connected auxiliary resonant snubber (NPC-ARS) circuit. The proposed NPC-ARS circuit consists of an active power semiconductor devices; S_a , a resonant capacitor C_r , two power diode D_{a1} and D_{a2} . Using this NPC-ARS circuit, the zero voltage soft switching (ZVS) turn off or the zero current soft switching (ZCS) turn on can be achieved in main switching device S_1 and ZCS turn on and turn off be in auxiliary switch S_a . So that, the switching losses in each active power semiconductor device will be zero completely.

III. OPERATION PRINCIPLE OF NPC-ARS CIRCUIT

The operation principle of the proposed forward type soft switching DC-DC converter with the NPC-ARS circuit is illustrated in Fig.1.c. The conventional forward type DC-DC converter operates only two circuit condition modes which are described in Fig.1.c as the steady state mode on and off. On the other hand, there are 4 modes in case of the proposed one as depicted in Fig.1.c. The operating principle of the proposed forward type soft switching DC-DC converter is described as follows:

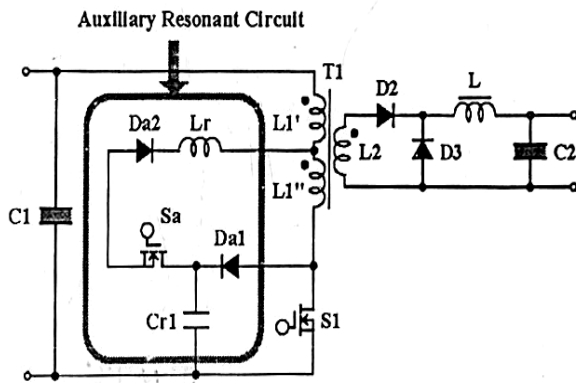

Fig.1.b: Forward type soft switching DC-DC converter with a neutral point inductor connected auxiliary resonant snubber (NPC-ARS) circuit.

Steady State Mode ON: In this state, the transformer current flows through the main active power semiconductor device S_1 and the primary energy conducts to secondary side of transformer. If the main active power semiconductor device S_1 is turned off, the operation mode changes to the next circuit condition mode, Commutation Mode 1.

Commutation Mode 1: The energy in the leakage inductance of transformer T_1 is flowing through the resonant capacitor C_r by turned main active power semiconductor devices S_1 off. When the leakage inductance current reach zero, the operation mode changes to the next steady state mode, Steady State Mode off.

Steady State Mode OFF: The energy in the primary side of

transformer is broken off the secondary side in this circuit condition mode. If the main active power semiconductor device S_1 and auxiliary active power semiconductor device S_a are turned on the operation mode changes to the next circuit condition mode, Commutation Mode 2.

Commutation Mode 2: In this mode, the active power semiconductor devices S_1 and S_a can be achieved the complete ZCS transition by the leakage inductance and auxiliary resonant inductor L_r . The energy in the primary side of transformer T_1 is conducted to the secondary side. Furthermore, the energy in the resonant capacitor C_r flow to the secondary side of the transformer through the transformer T_1 . When the voltage of the resonant capacitor C_r reaches zero, the operation mode is changed to the first circuit condition mode, Steady State Mode on.

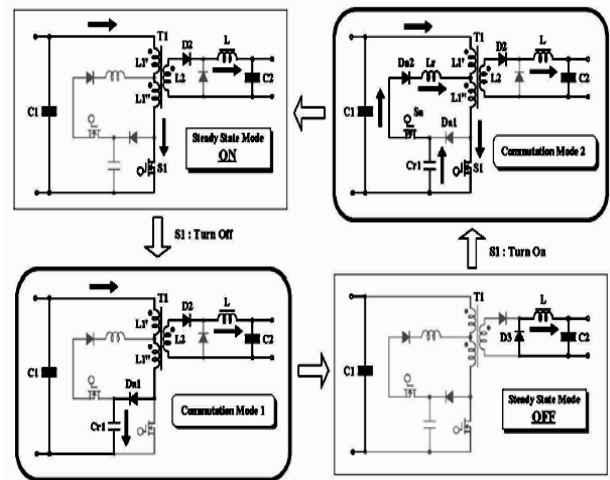

Fig.1.c: Equivalent circuit for each operation stage of the proposed forward type soft switching DC-DC converter with the NPC-ARS circuit.

IV. MATHEMATICAL DESIGN FOR NPC-ARS CIRCUIT

When the main switch $M1$ is turned on at zero current as shown in Fig.3.g. input dc gets applied to the primary winding and simultaneously a scaled voltage appears across the transformer secondary. When the main switch $M1$ is turned off at zero voltage as shown in Fig.3.g. The leakage inductance of a transformer and a voltage stress on the main switch is stored in the capacitor C_r by the diode D_{a1} and takes a path through the capacitor C_r and to the transformer $L1'$ up to the leakage inductance current reaches zero. The stored energy of the Capacitor C_r is freewheels when the main and auxiliary switches are turned on at zero current.

The assumptions for the NPC-ARS auxiliary switch in the forward converter are:

Frequency $f = 100$ kHz, $\Delta I = 2.5$, and $R = 100 \Omega$. By using the relation $1 - \delta = V_i / V_o$, we get $\delta = 0.5$.

By use the formula $L = V_i \delta / f \Delta I$, we get $L = 200$ mH and

by the relationship $C = \delta / 2 f_r$, we get $C = 250 \mu\text{F}$ and the voltage transformer ratio $V_o / V_i = K$, as by using this relationship we get the value of $K=0.21$.

The transformer primary voltage $E_1 = 4.44 * N_1 * \Phi * f$. By solving the equation to get the value of $N_1 = 4.5$, and by the equation $N_2 = (E_2 / E_1) N_1$ to get the value of $N_2 = 9$.

V. SIMULATION RESULTS

The SMPS system is modelled and simulated using the blocks of MATLAB SIMULINK. The SMPS system using conventional boost and forward converters is shown in Fig.2.a. Diode rectifier with capacitor filter was represented as a DC source at the input. The current and voltage waveforms of S2 are shown in Fig.2.b. The voltage across the primary of the transformer is shown in Fig.2.c. The voltage across the secondary of the transformer is Fig.2.d, the voltage across the diode d3 is shown in Fig.2.e. From the waveforms it can be seen that the output contains noise.

Modified SMPS system using auxiliary switch in the forward converter is shown in Fig.3.a. The voltage and current waveform of S2 are shown in Fig.3.b. Voltage across the primary of the transformer is shown in Fig.3.c. The voltage across the secondary of the transformer is shown in Fig.3.d. The voltage across the diode D3 is shown in Fig.3.e. The pulse and voltage across the switch M2 is shown in Fig.3.f. The pulse and voltage across the switch M1 is shown in Fig.3.g. The Current across the inductor L1 is shown in Fig.3.h. The voltage across the capacitor C2 is shown in Fig.3.i. From the above waveforms it can be seen that the output is free from noise.

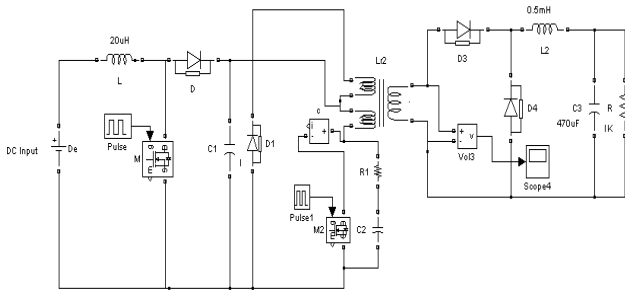

Fig.2.a: Conventional Boost & forward converter.

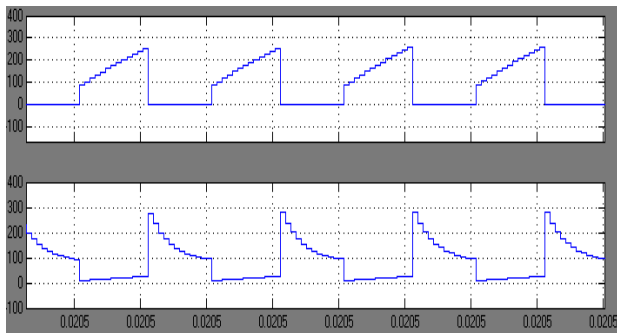

Fig.2.b: Current and voltage waveforms of S2.

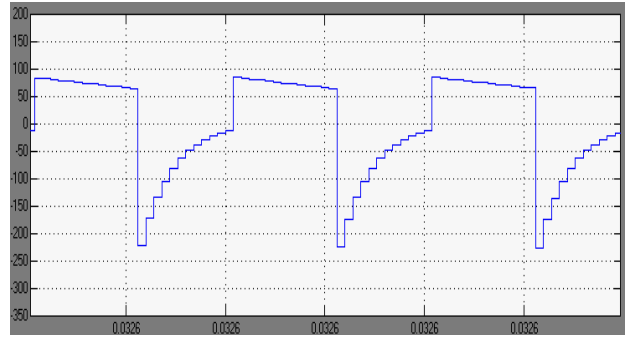

Fig. 2.c: Transformer primary voltage.

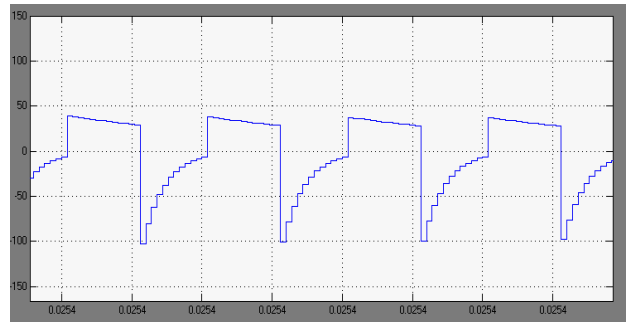

Fig.2.d: Transformer secondary voltage.

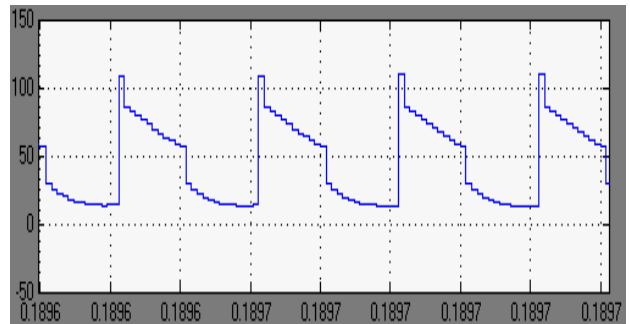

Fig.2.e: Voltage across diode D3.

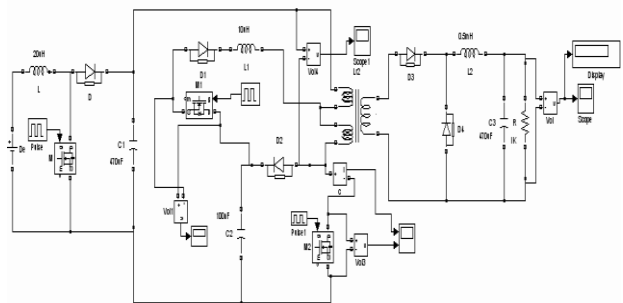

Fig.3.a: Modified SMPS system using auxiliary switch in the forward converter.

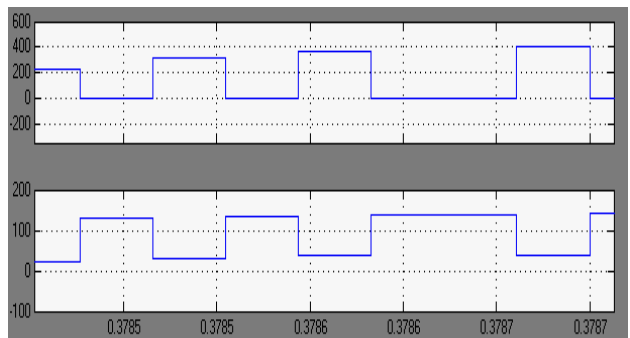

Fig.3.b: Current and voltage waveforms of S2.

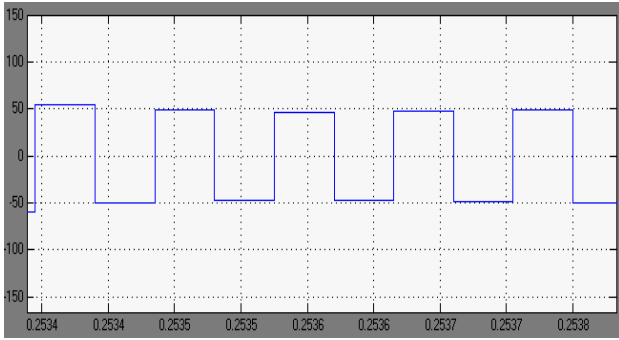

Fig.3.c: Transformer primary voltage.

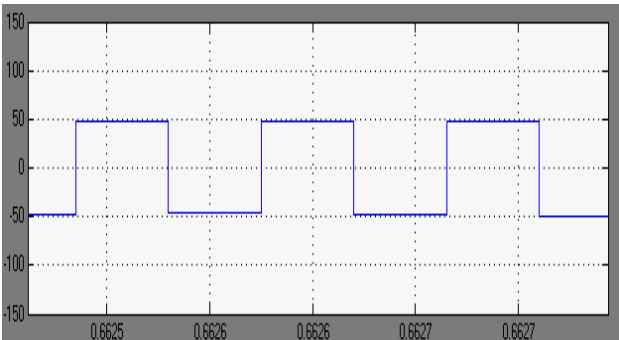

Fig.3.d: Transformer secondary voltage.

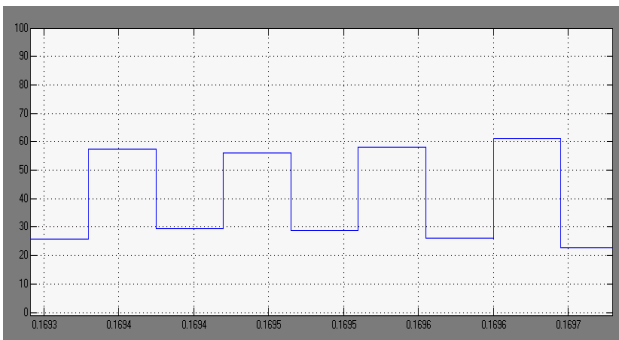

Fig.3.e: Voltage across diode D3.

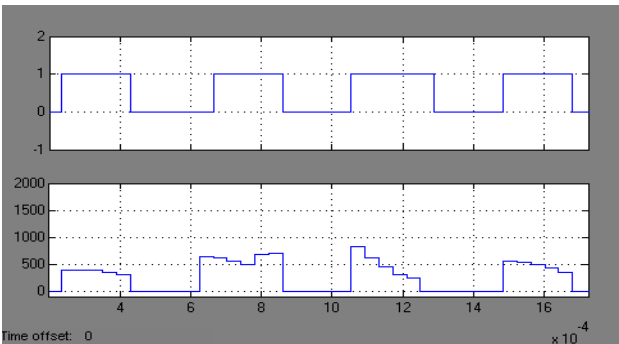

Fig.3.f: Pulse and voltage across the switch M2.

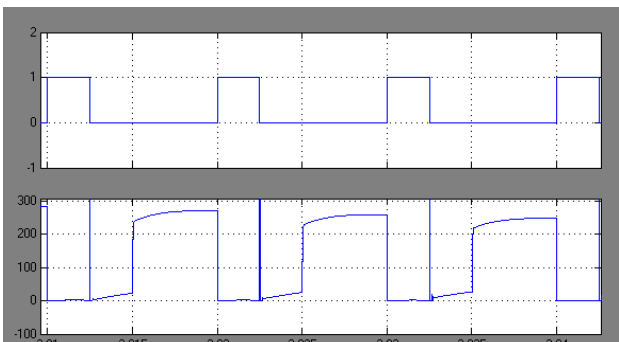

Fig.3.g: Pulse and voltage across the switch M1.

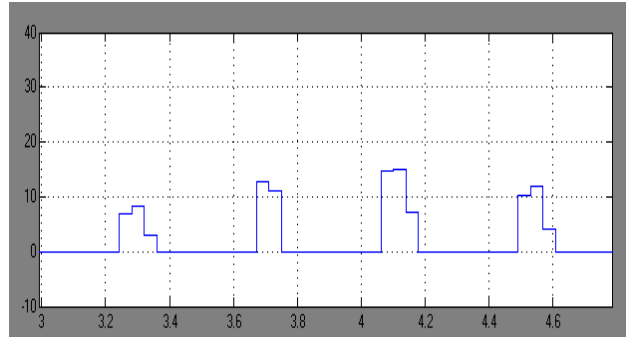

Fig.3.h: Current across the inductor L1.

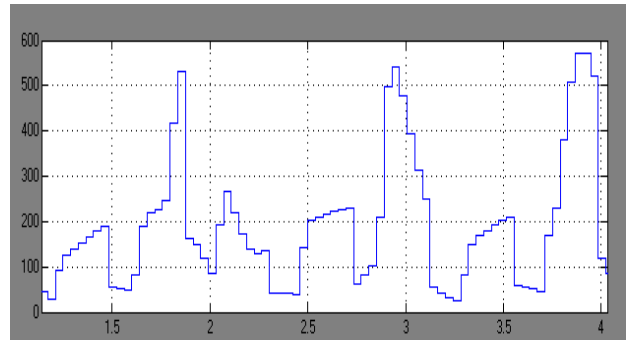

Fig.3.i: Voltage across the Capacitor C2.

VI. EXPERIMENTAL RESULTS

Low noise SMPS System with forward type soft switching DC-DC Converter with a neutral point inductor connected auxiliary resonant snubber circuit is designed and the hardware module is shown in Fig.4.a. The Atmel Microcontroller 89C2051 is used to generate the driving pulses for the thyristor S_a and S_1 as shown in the oscillogram of Fig.4.b and Fig.4.c. The Boost up driving pulses as shown in the oscillogram of Fig.4.d.

The transformer Primary voltages at the input with disturbances and the transformer secondary voltages at the output with disturbances as shown in the oscillogram of Fig.4.e. and Fig.4.f. The DC output voltage as shown in the oscillogram of Fig.4.g. The inductor current in NPC-ARS circuit is shown in Fig.4.h. The Capacitor voltage in NPC-ARS circuit is shown in Fig.4.i. The important circuit parameters of conventional circuit are indicated in TABLE 1. The circuit parameters in the proposed one are in TABLE 2. The experimental results are obtained for constant load.

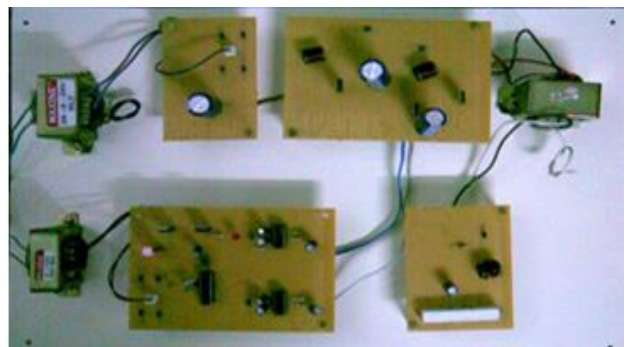

Fig.4.a: Hardware Module.

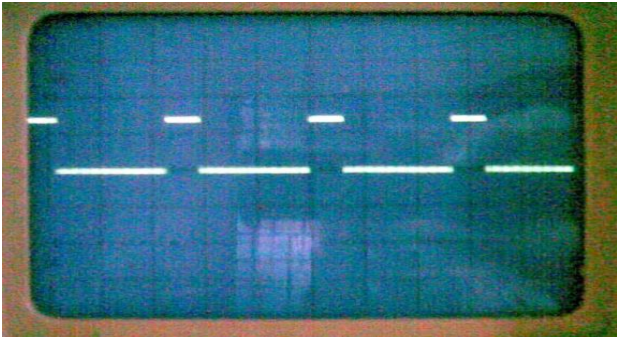

Fig.4.b: Driving Pulse of S_a .

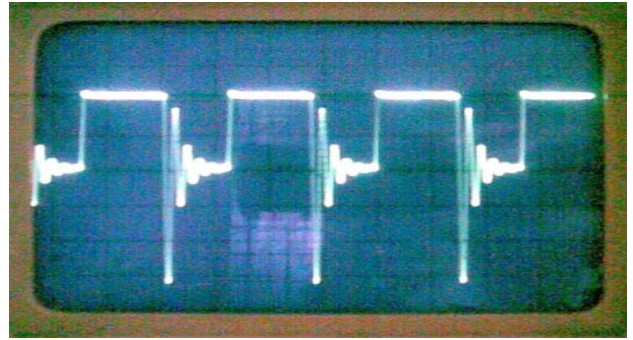

Fig.4.f: Transformer Secondary Voltage.

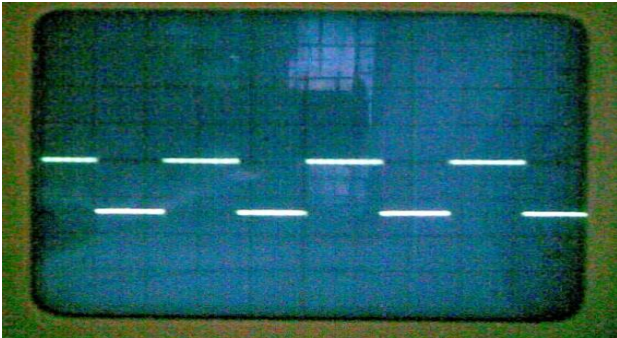

Fig.4.c: Driving Pulses of S_1 .

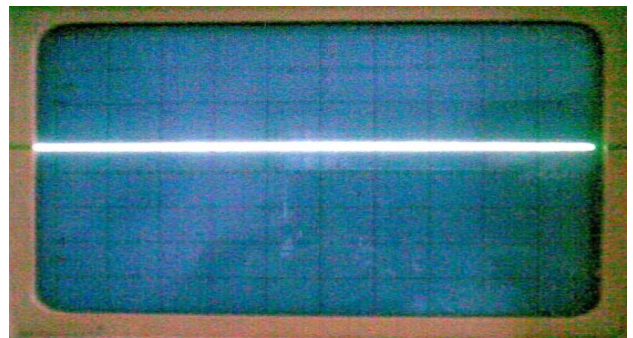

Fig.4.g: DC Output Voltage.

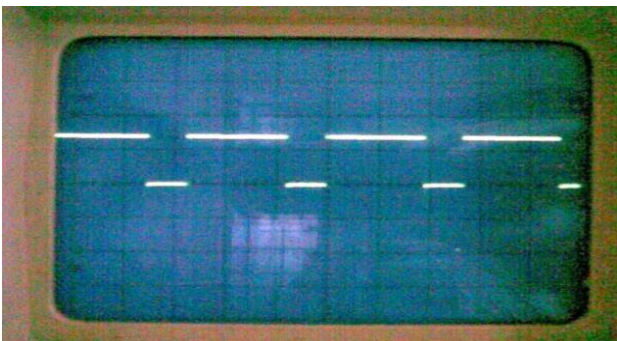

Fig.4.d: Driving Pulses of Boost Transistor.

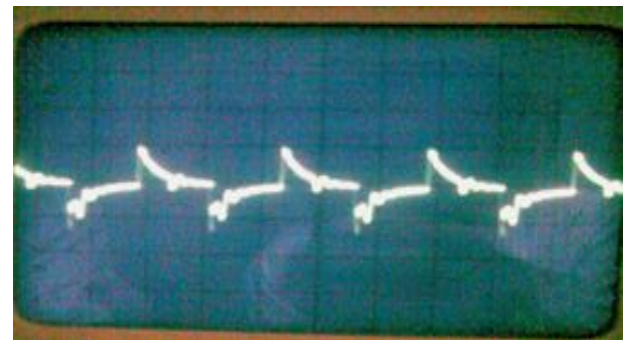

Fig.4.h: Inductor Current in NPC-ARS Circuit.

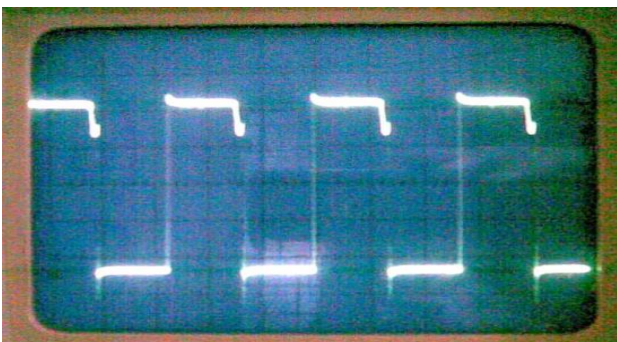

Fig.4.e: Transformer Primary Voltage.

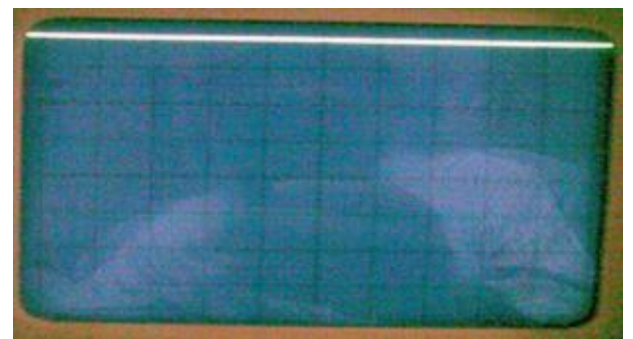

Fig.4.i: Capacitor Voltage in NPC-ARS Circuit.

Table 1: Circuit Parameters for Conventional Circuit

Parameters	Unit	Values and Items
Input Voltage	[V]	48
Output Voltage V_o	[V]	18
Switching frequency	[kHz]	30
Smoothing Capacitor $C1, C2$ [μf]/V		2200/63,100/63
Smoothing Inductor L [mH]		27
Capacitance of Snubber circuit		1000 μF /63 V
Resistance of Snubber circuit		330 ohm/20W
Power MOSFET		IRF 840
Power Diode		IN4007

Table 2: Circuit Parameters for Proposed Circuit

Parameters	Unit	Values and Items
Input Voltage	[V]	48
Output Voltage V_o	[V]	18
Switching frequency	[kHz]	30
Smoothing Capacitor $C1, C2$ [μf]/V		2200/63,100/63
Smoothing Inductor L [mH]		27
Inductance of NPC-ARS circuit [μH]		10
Capacitance of NPC-ARS circuit [nf]		100
Power MOSFET		IRF 840
Power Diode		IN4007

VII. CONCLUSION

Implementation of low noise SMPS System using forward converter with MATLAB-SIMULINK was done using microcontroller. Modified circuit configuration of forward type DC-DC converter with its working principle is presented in this paper. The conventional and modified SMPS systems are digitally simulated using Sim power systems. The simulation results and the experimental results are compared. The modified converter has reduced noise in the output. From the results, it is observed that the experimental results closely agree with the simulation results.

REFERENCES

- [1] Tamer T.N.Khabib, Azah Mohamed, Nowshad Admin, "A New Controller Scheme for Photo voltaics power generation system," *European journal of scientific research* ISSN 1450-216X vol.33 No.3 (2009), pp.515-524.
- [2] J.Morroni, R.Zane, D.Maksimovic, "Design and Implementation of an adaptive tuning system based on desired phase margin for digitally controlled DC-DC Converters," *IEEE Trans. Power Electron.*, vol.24, no.2, pp.559-564, feb.2009.
- [3] M.Shirazi, J.Morroni, A.Dolgov, R.Zane, D.Maksimovic, "Integration of frequency response measurement capabilities in

P. Vijaya Kumar et. al: Simulation and Experimental Results...

- digital controllers for DC-DC Converters," *IEEE Trans. Power Electron.*, vol.23, no.5, pp.2524-2535, sep.2008.
- [4] Hugo Ribeiro, Beatriz V.Borges, "New single stage, single phase, full Bridge Converter," submitted for appreciation to the Technical committee of IEEE ECCE-Energy conversion congress and exhibition, January 2009.
- [5] Y.Yin, M.Shirazi, R.Zane, "Electronic Ballast control IC with digital phase control and lamp current regulation," *IEEE Trans. Power Electron.*, vol. 23, no.1, pp.11-18, jan.2008.
- [6] Yungtaek Jang, David L.Dillman and Milan M.Javanovic, "A New soft-switched PFC Boost Rectifier with Integrated Flyback Converter for stand-by Power," *IEEE Trans. on Power Electron.*, pp.66-72, No.1, 2006.
- [7] M. Belloni, E. Bonizzoni, and F. Maloberti, "On the Design of Single-Inductor Multiple-Output DC-DC Buck Converters", Proc. of 2008 International Symposium on Circuit and Systems (ISCAS), pp. 3049-3052, May 2008.
- [8] S. Kapat, A. Patra, and S. Banerjee, "A Current Controlled Tri-State Boost Converter with Improved Performance through RHP Zero Elimination", *IEEE Trans. on Power Electron.*, vol. 24, no.3, pp. 776-786, March 2009.
- [9] R.J. Wai, C. Lin and Y. Chang, "High-efficiency dc-dc converter with high voltage gain and reduced switch stress," *IEEE Trans. on Power Electron.*, vol. 54, no.1, Feb., 2007.
- [10] S.Havanur, "Snubber design for noise reduction in switching circuits," Alpha & Omega Semiconductor, Tech. Rep., 2007.
- [11] S.Abe, T. Ninomiya, Comparison of Active-Clamp and ZVT Techniques Applied to Tapped-Inductor DC-DC Converter with Low Voltage and High Current, *Journ. of Power Electron.*, vol.2, no.3, pp.199-205, 2002.
- [12] Arturo Fernandez, Javier sebastin, Maria Hernando, "Multiple output AC/DC Converter with an Internal DCUPS," *IEEE Trans on Ind. Electron.* vol.53.no.1.Feb.2006.
- [13] Aggeler, D-; Inove, S-; Akagi, H-; Kolar, J.W, "Bi directional isolated DC to DC Converter for next generation power distribution-comparison of converters using Si and Sic devices "Power conversion conference-agoya.2007.PCC apos;, vol.7, Issue2-5, pp:510-517, April 2007.

BIOGRAPHIES



P.Vijayakumar received his Diploma in Electrical and Electronics Engineering from A.S.A Polytechnic, Tenkasi, affiliated to DOTE, Chennai, India in 1996 and B.E degree in Electronics and Communication Engineering from V.R.S College of Engineering and technology, Madras University, Chennai, India in 2002 and M.Tech degree in Power Electronics and Drives from Bharath Institute of Higher Education and Research, Bharath University, Chennai, India in 2005. Currently he is Pursuing Ph.D degree in Jawaharlal Nehru Technological University, Hyderabad, India. He has 9 years of teaching experience and 3 years of Industrial experience and he is a member of IEEE. His research area is on SMPS System.



S.RamaReddy received his M.E degree from College of Engineering, Anna University, Chennai, India in 1987. He received Ph.D degree in the area of Resonant Converters from College of Engineering, Anna University, Chennai, India in 1995. Presently he is working as Dean in Electrical and Electronics Department, Jerusalem College of Engineering, Chennai. He has worked in Tata Consulting Engineers and Anna University, Chennai, India. He is fellow member of Institution of Electronics and Telecommunication Engineers (India),

Life Member of Institution of Engineers (India), Member of ISTE, Member of CSI and Member of SPE, India. He has authored text books on Power Electronics, Electronic Circuits and Electromagnetic Fields. He has Published 30 research papers in reputed journals. His research areas are Power Electronic Converters, Drives and FACTS.